

DOVER WRC (8.4)

USE PURPLE 48VDC POSITIVE GROUND Board only.

Blue numbers on the wiring diagrams correspond to the Blue instruction .RED X indicates a cut in the circuit you must make

NOTE: THIS SYSTEM USED A POSITIVE GROUND. BE SURE THAT 48VDC+ USES SP SIDE OF THE LINE, and 48VDC- USES THE SN SIDE The relay used for RELAY ADDS should should be coil only if possible. If it has more than a coil (LED, DIODE etc) be sure to polarize it correctly!

Step	Wire#	Instruction
1		SEE STP_RELAY ADD BELOW
2		SEE STP_RELAY ADD BELOW
3		Connect to the “KEYSW FEED” terminal on the FS90 Board that is CLOSEST to end of the terminal block
4		Connect to the remaining “From KEYSW” terminals on the FS90 Board
5		Connect to the PHIISIG TERMINAL on the FS90 Board
6		SEE CC RELAY ADD ON BELOW
7		SEE CC RELAY ADD ON BELOW
8		Connect Dover SP TERMINAL to the 48VDC+ TERMINAL on the FS90 Board
9		Connect Dover SN TERMINAL to the 48VDC- on the FS90 Board
10		See HAT_RELAY ADD ON BELOW
11		See HAT_RELAY ADD ON BELOW
12		Connect to the KEY/HAT TERMINAL on the FS90 Board
13		Connect to the DZ_SIG TERMINAL on the FS90 Board

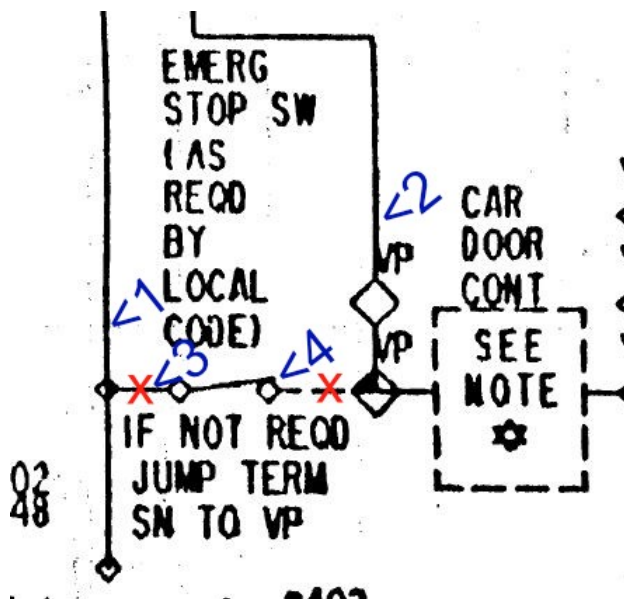

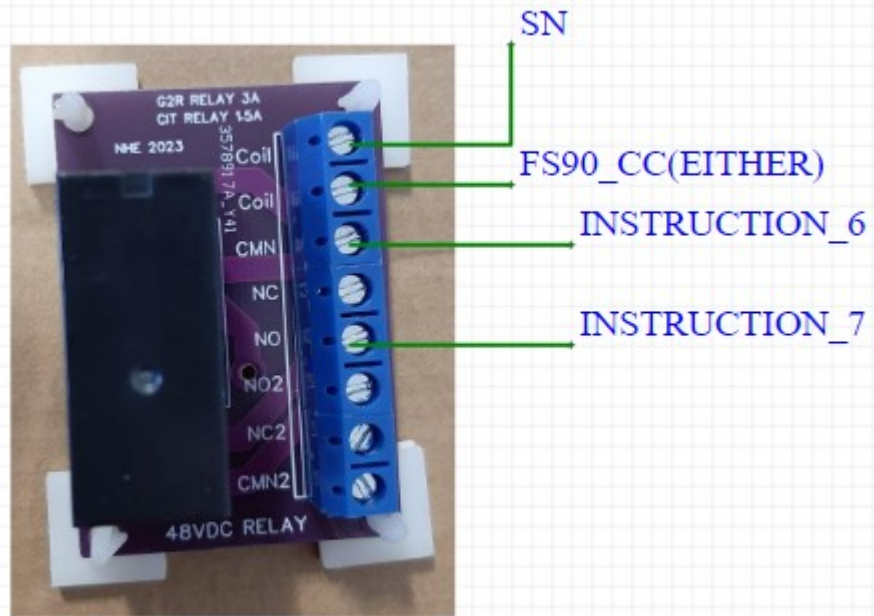
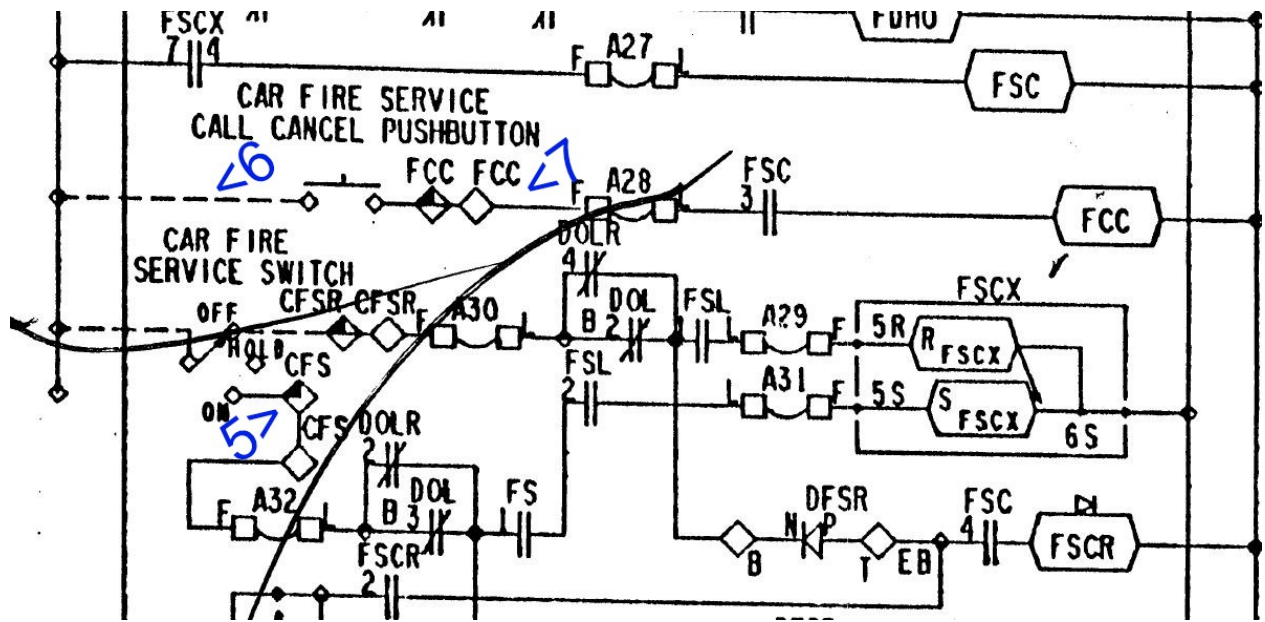

CC RELAY ADD

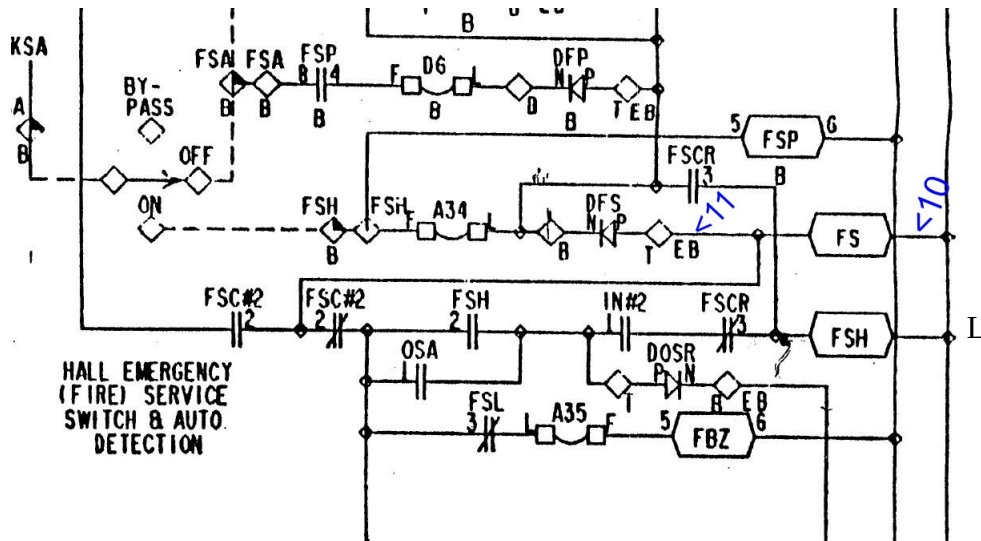
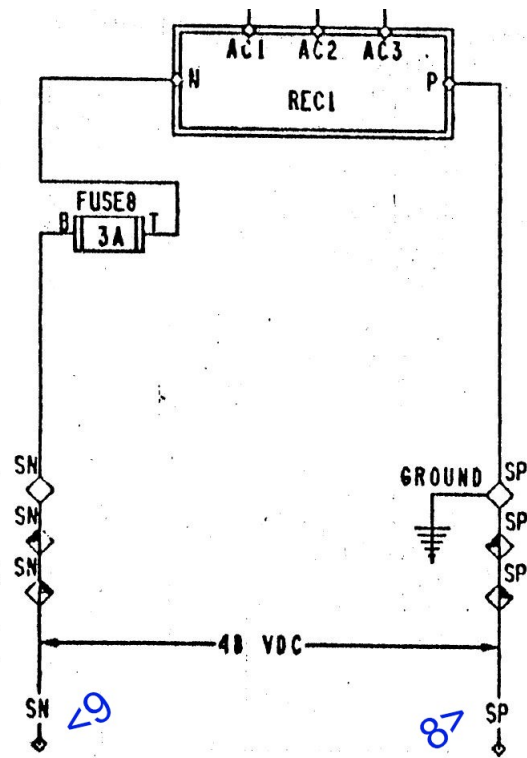

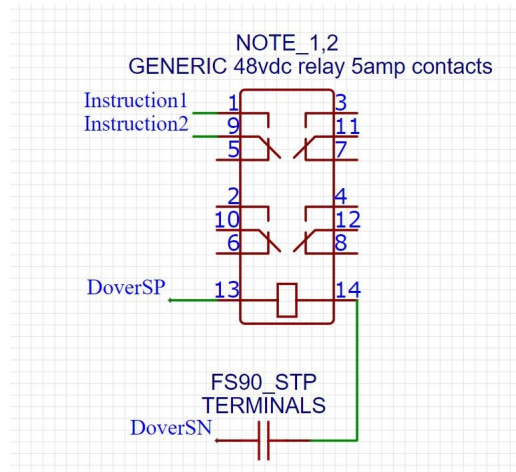

HAT_RELAY ADD

